

nES SERIES SINGLE STAGE ROTARY VANE PUMPS

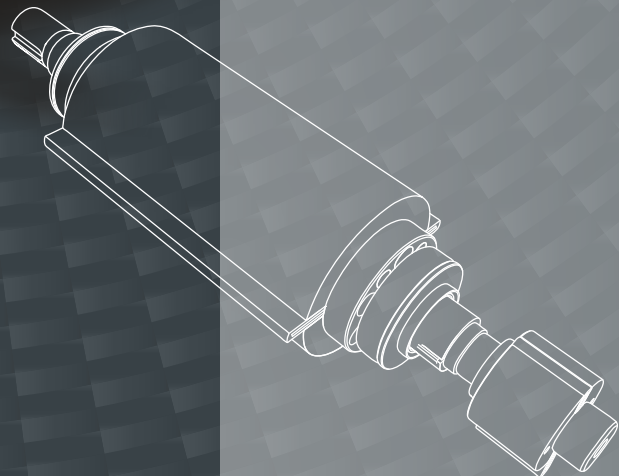
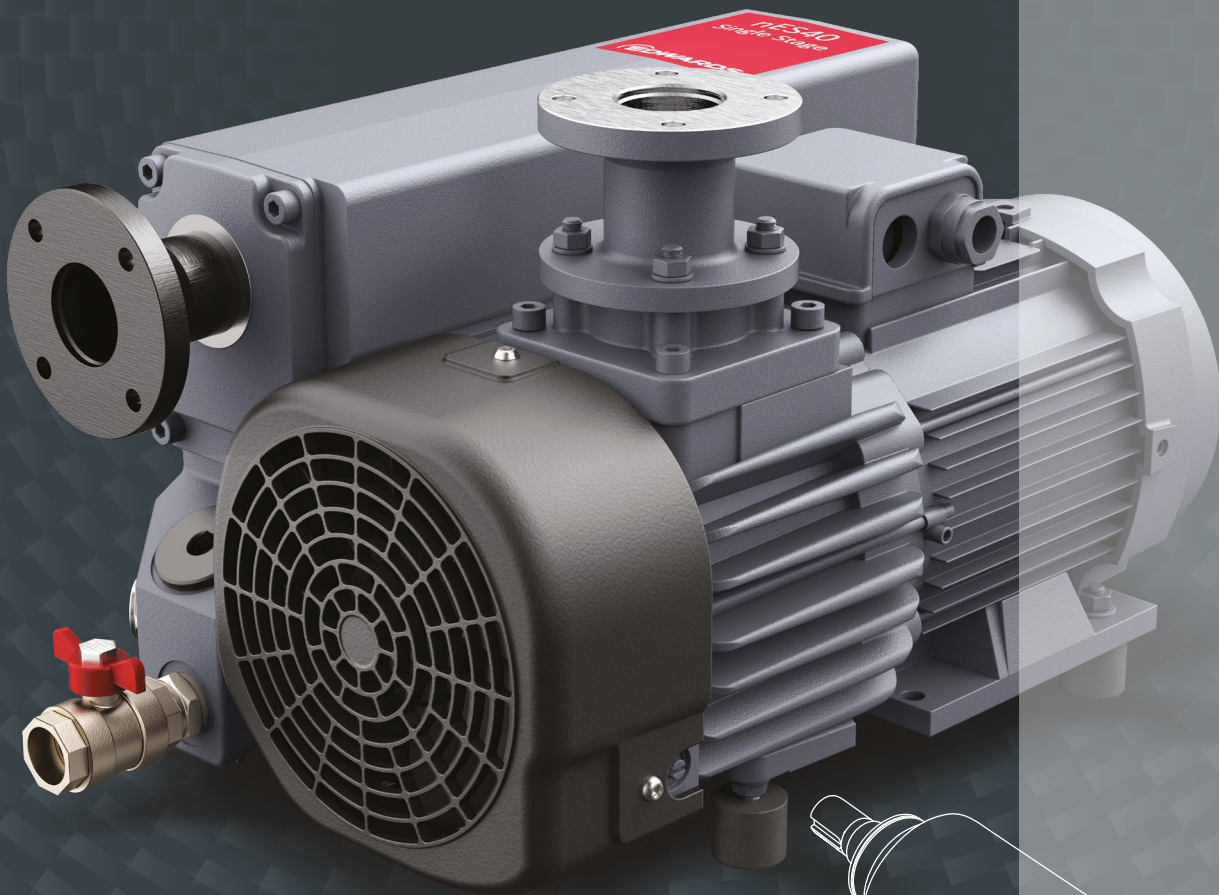

EDWARDS THE PARTNER OF CHOICE

Edwards is a world leader in the design, technology and manufacture of vacuum pumps for industrial applications with over 100 years' history.

We believe in delivering results that bring value to our customers by using our breadth of industry experience to identify and apply solutions. Using the most innovative and up-to date modelling techniques, we can optimise the pumping configuration for customers to provide a system design giving the maximum performance in the most reliable and cost-effective way.

nES SERIES

NEXT-GENERATION SINGLE STAGE ROTARY VANE PUMPS

The Edwards nES single stage series represents the next advancement in oil-sealed rotary vane vacuum pumps for use in a wide range of industries and applications.

Offering high reliability, low life cycle cost and proven performance, the nES series provides an ideal solution to suit a broad range of requirements.

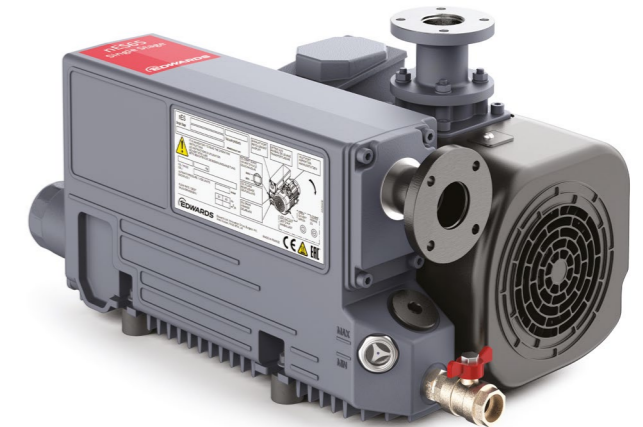
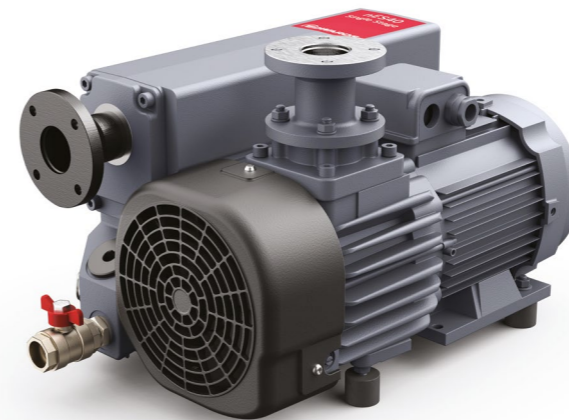

FEATURES



PROVEN PERFORMANCE

The Edwards nES series delivers consistent pumping performance with excellent vacuum stability, thanks to optimised oil distribution. A high pumping speed at low pressures provides an ideal solution for a wide range of applications.



HIGH RELIABILITY

The pump mechanism provides high robustness and reliability, ensuring maximum productivity. Engineered with high-quality components and an effective oil return system, the nES series is designed to maximise process efficiency.



LOW LIFE CYCLE COST

Efficient cooled motors, low pump temperature and minimum maintenance provide an excellent life cycle cost.



LOWER EMISSIONS

The nES series is compact in design and clean in operation with highly efficient integrated mist filters, optimised oil retention, low noise and vibration level to minimise environmental impact.



nES300



nES750



nES220

nES PUMP TECHNOLOGY

PUMP MECHANISM

The pump mechanism is designed to provide optimum pumping performance without fluctuation in vacuum levels.

EFFICIENT COOLING

The efficient cooling system enables low operating temperatures and increased oil life, improving reliability.

OIL RETURN SYSTEM

The optimised return and separation system supports a stable pumping performance and minimises oil loss. Use of the ULTRAGRADE Performance 70 oil enables optimum pumping performance, while the use of the ULTRAGRADE Endurance Extend 110 oil provides extended service intervals.

GAS BALLAST

The gas ballast mechanism facilitates effective pumping and management of condensable vapours.

DRIVE TECHNOLOGY

The motors are highly efficient, meeting latest efficiency standards and UL and European standards.

INSTALLATION FLEXIBILITY

The pumps are compatible with both ISO and G connections, providing flexibility in installation.

ADVANTAGES



High pumping speed at low pressure



Stable vacuum performance with no pressure fluctuation



Low noise and vibration



Efficient oil distribution system



High reliability through proven technology



Compact design with integrated motor



Simplified maintenance - ensuring high productivity

TECHNICAL DATA

	Units	nES40	nES65	nES100	nES220
Maximum displacement (50 Hz)	m ³ h ⁻¹ /cfm	44.0/25.9	59.0/34.8	98.0/57.4	200/117
Maximum displacement (60 Hz)	m ³ h ⁻¹ /cfm	53.0/31.2	71.0/41.8	117/68.9	240/141
Pumping speed (50 Hz)	m ³ h ⁻¹ /cfm	38.5/22.7	54.0/31.8	87.5/51.5	179/105
Pumping speed (60 Hz)	m ³ h ⁻¹ /cfm	47.0/27.7	64.0/37.7	105/61.8	214/125
Ultimate vacuum without gas ballast	mbar/torr	0.5/0.4	0.5/0.4	0.5/0.4	0.08/0.06
Ultimate vacuum with gas ballast	mbar/torr	1.5/1.1	1.5/1.1	1.5/1.1	0.7/0.5
Inlet connection	ISO/G	40 ISO-F/G1 ¼	40 ISO-F/G1 ¼	40 ISO-F/G1 ¼	63 ISO-F/G2
Outlet connection	ISO/G	40 ISO-F/G1 ¼	40 ISO-F/G1 ¼	40 ISO-F/G1 ¼	63 ISO-F/G2
Max. permitted outlet pressure	bar (abs)	1.15	1.15	1.15	1.15
Max. water vapour pumping rate (50 Hz)	kg ^h ⁻¹ /lbh ⁻¹	0.76/1.67	1.0/2.2	1.60/3.5	1.3/2.8
Max. water vapour pumping rate (60 Hz)	kg ^h ⁻¹ /lbh ⁻¹	0.90/2.0	1.25/2.75	1.70/3.75	1.8/4.0
Dimensions (LxWxH) approximate	mm	540x284x303	586x320x314	721x400x319	984x606x407
Weight approximate	kg/lb	67/148	86/190	104/230	180/397
Motor protection rating		IP55	IP55	IP55	IP55
Motor rated power (50 Hz)	kW	1.3	1.8	3	4.4
Motor rated power (60 Hz)	kW/hp	1.3/2	1.8/3	3.6/5	5.5/7.5
Cooling		air	air	air	air
Noise level (50 Hz) air/water	dB(A)	58	60	61	69
Noise level (60 Hz) air/water	dB(A)	60	64	64	73
Oil refill capacity	litre	1	2	2	7.5
Recommended oil	Edwards ULTRAGRADE Performance 70 or ULTRAGRADE Endurance Extend 110				

	Units	nES300	nES300S	nES630	nES750
Maximum displacement (50 Hz)	m ³ h ⁻¹ /cfm	280/165	330/194	700/412	840/494
Maximum displacement (60 Hz)	m ³ h ⁻¹ /cfm	340/200	385/227	840/494	-
Pumping speed (50 Hz)	m ³ h ⁻¹ /cfm	240/141	284/167	640/377	755/444
Pumping speed (60 Hz)	m ³ h ⁻¹ /cfm	290/171	330/194	755/444	-
Ultimate vacuum without gas ballast	mbar/torr	0.08/0.06	0.08/0.06	0.08/0.06	0.08/0.06
Ultimate vacuum with gas ballast	mbar/torr	0.7/0.5	0.7/0.5	0.7/0.5	0.7/0.5
Inlet connection	ISO/G	63 ISO-F/G2	63 ISO-F/G2	100 ISO-K/100 PN10	100 ISO-K/100 PN10
Outlet connection	ISO/G	63 ISO-F/G2	63 ISO-F/G2	100 ISO-K/100 PN10	100 ISO-K/100 PN10
Max. permitted outlet pressure	bar (abs)	1.15	1.15	1.15	1.15
Max. water vapour pumping rate (50 Hz)	kg ^h ⁻¹ /lbh ⁻¹	1.3/2.8	1.3/2.8	17/37.5	24/53
Max. water vapour pumping rate (60 Hz)	kg ^h ⁻¹ /lbh ⁻¹	1.8/4.0	1.8/4.0	24/53	-
Dimensions (LxWxH) approximate	mm	1130x555x450	1117x565x450	1563x909x740	1563x909x740
Weight approximate	kg/lb	244/539	244/539	760/1678	760/1678
Motor protection rating		IP55	IP55	IP55	IP55
Motor rated power (50 Hz)	kW	5.5	6	18.5	18.5
Motor rated power (60 Hz)	kW/hp	6.6/10	7.2/10	18.5/25	-
Cooling		air	air	air/water	air/water
Cooling water flow (if applicable)	L/h	72	72	750	750
Noise level (50 Hz) air/water	dB(A)	76	76	72/72	75/72
Noise level (60 Hz) air/water	dB(A)	8.5-11.5	8.5-11.5	75/72	-
Oil refill capacity	litre	20	20	20-23	20-23
Recommended oil	Edwards ULTRAGRADE Performance 70 or ULTRAGRADE Endurance Extend 110				

For water cooled versions: inlet/outlet connection M22 x 150 female, water supply pressure 2/8 bar, max water temperature 30°C

DIMENSIONS

nES40

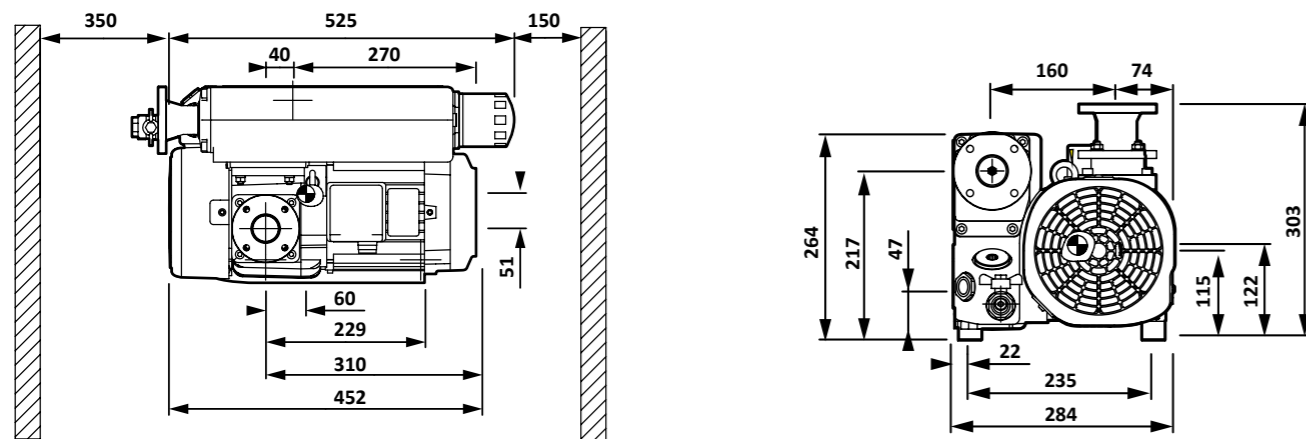

nES65

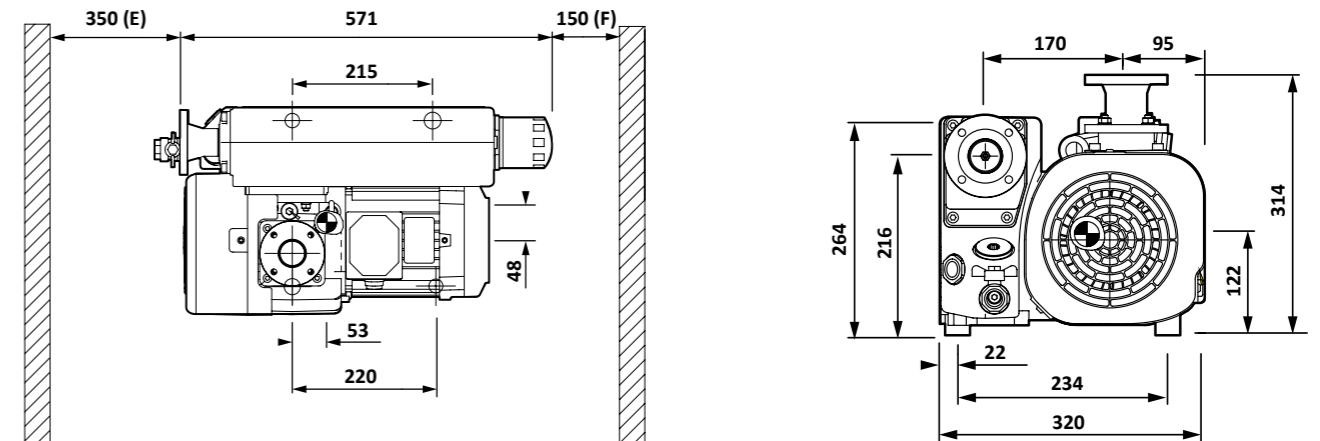

DIMENSIONS

nES100

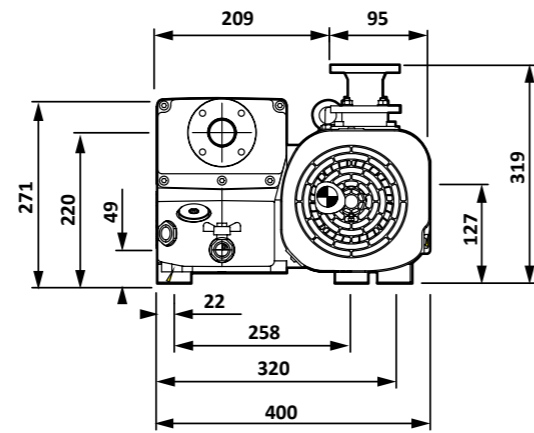
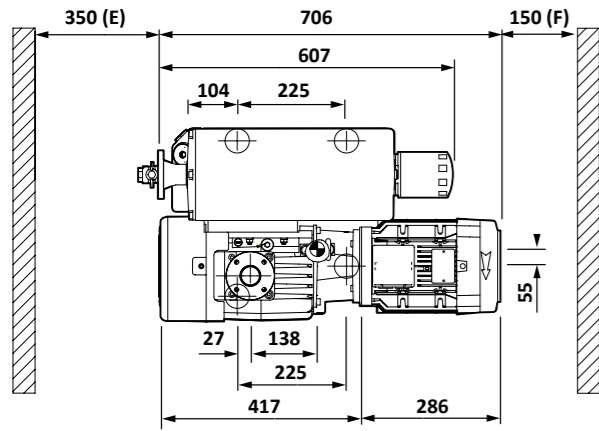

nES300S

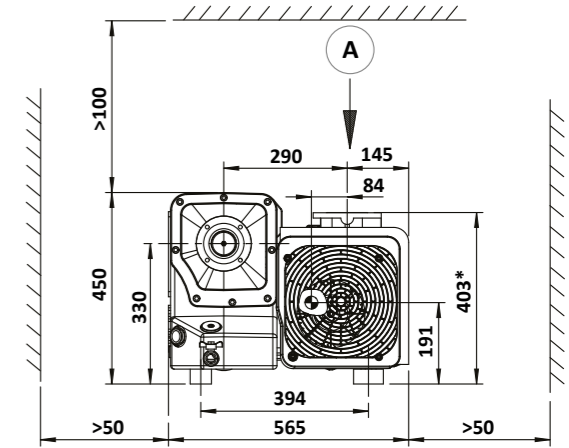
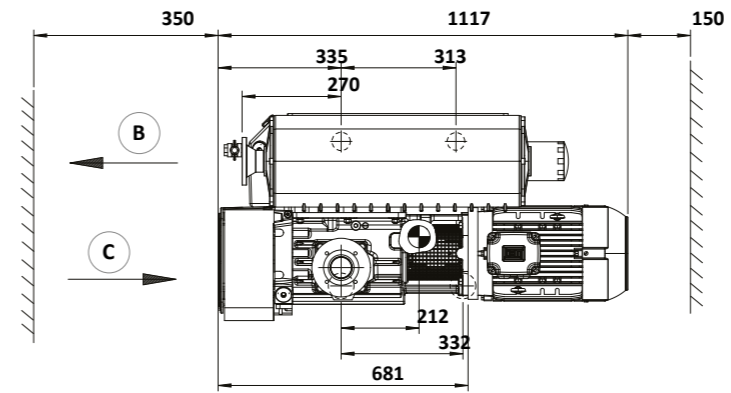

nES220

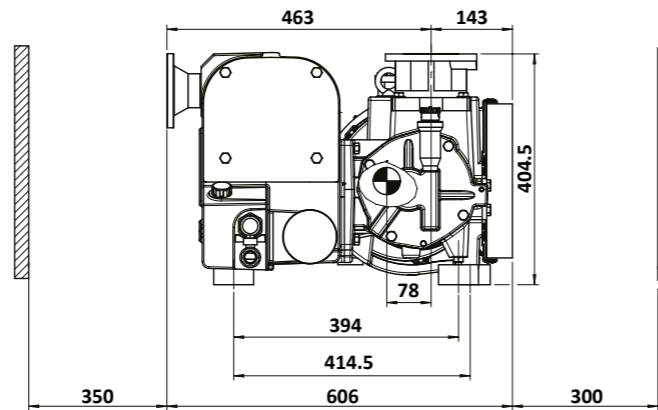
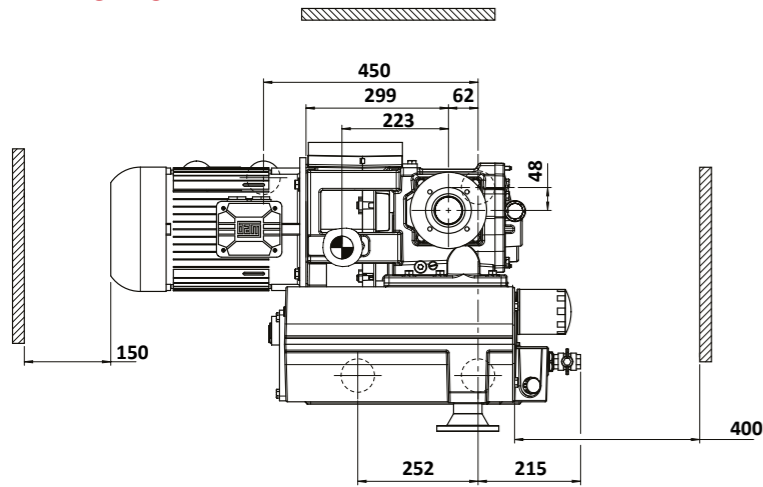

nES630/nES750

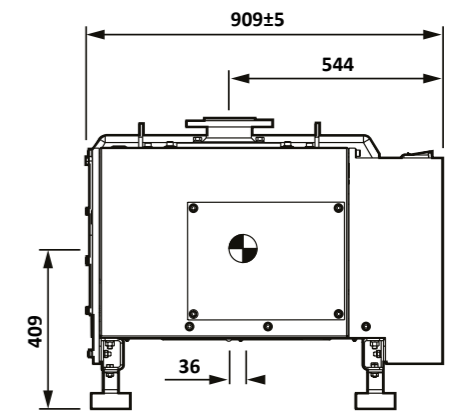
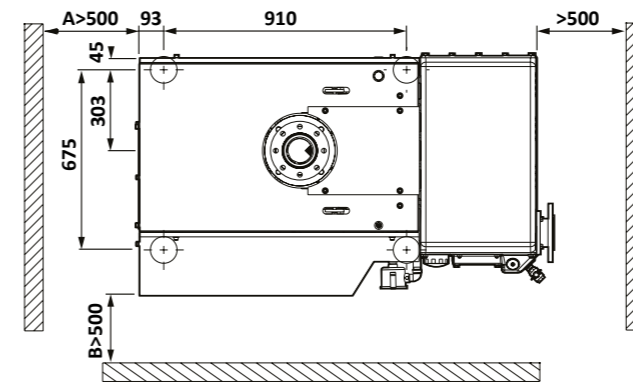

nES300

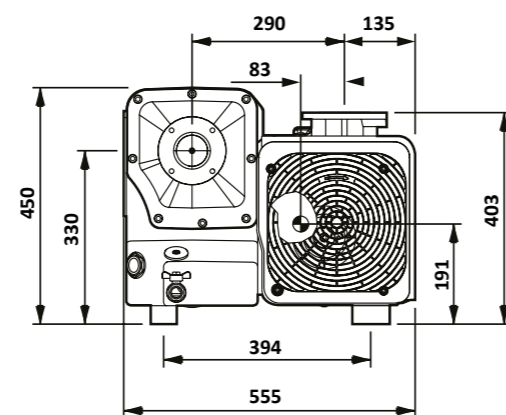
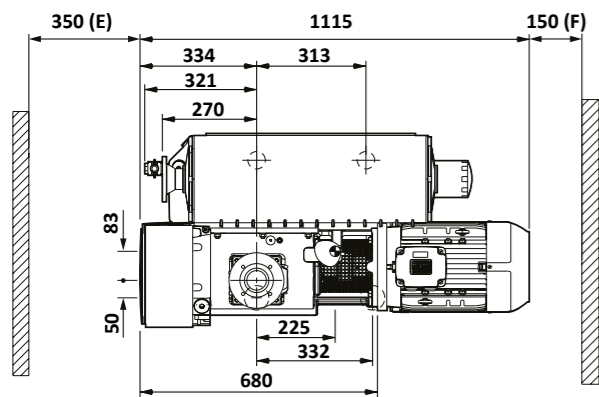

PERFORMANCE CURVES

nES40

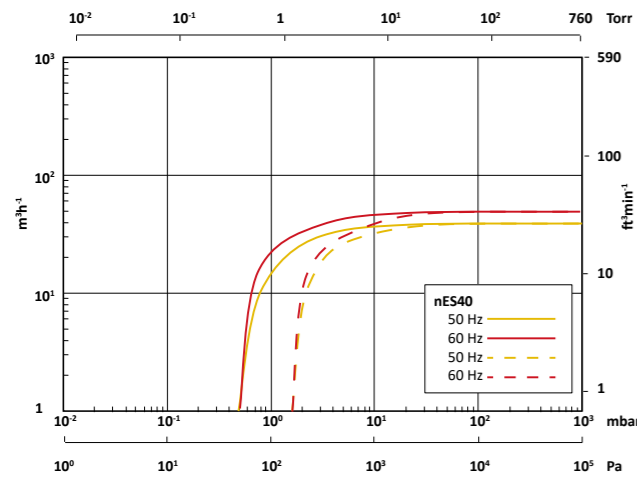

nES65

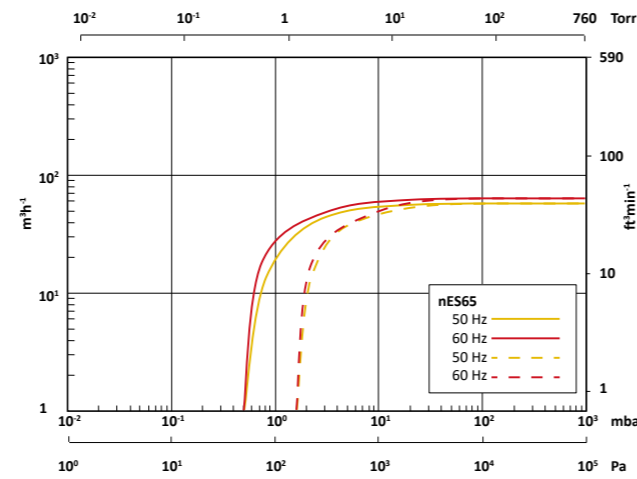

nES300

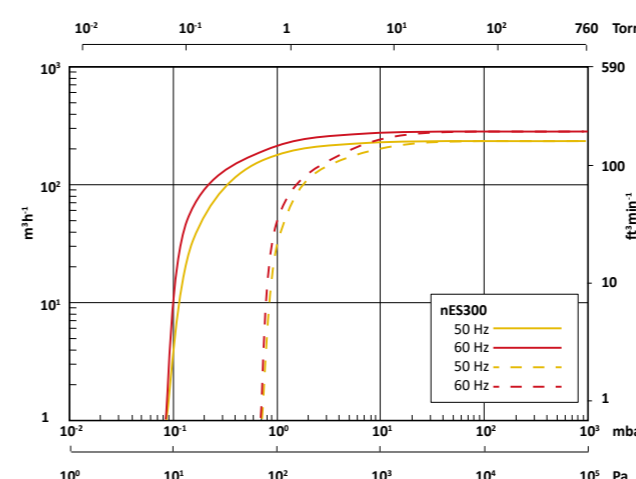

nES300S

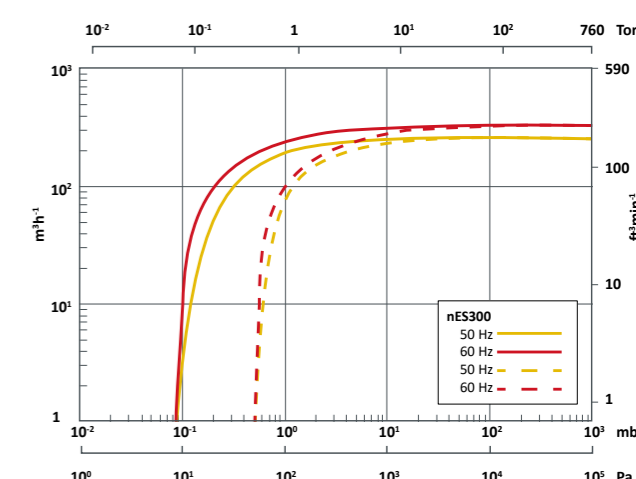

nES100

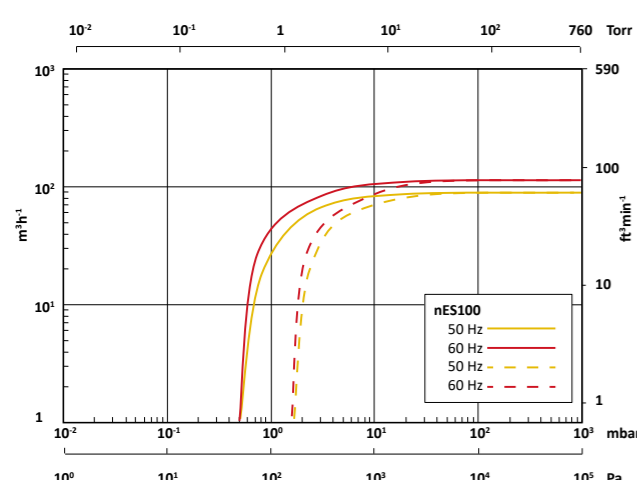

nES220

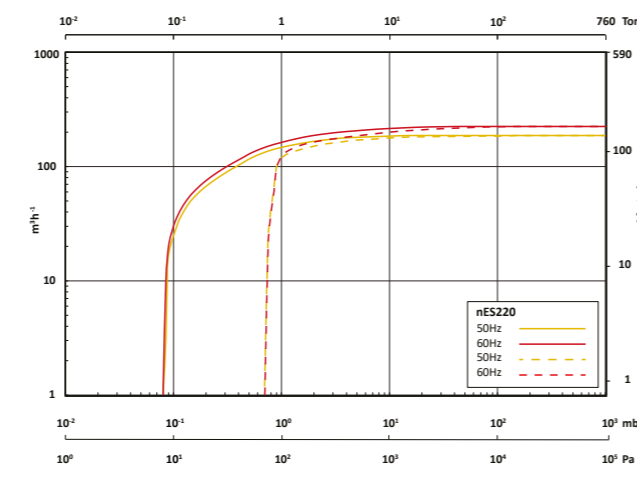

nES630

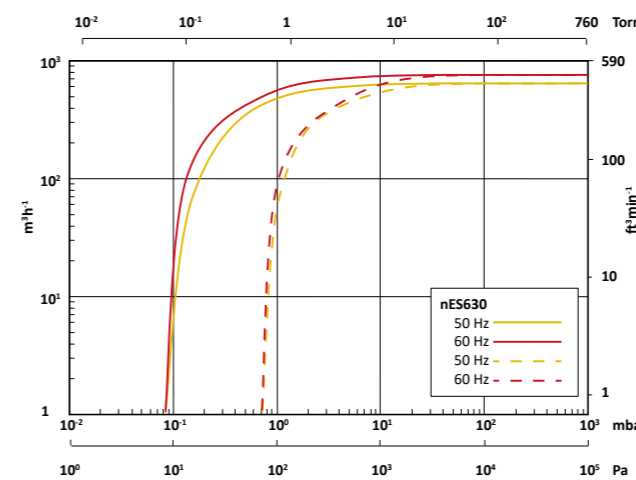

nES750

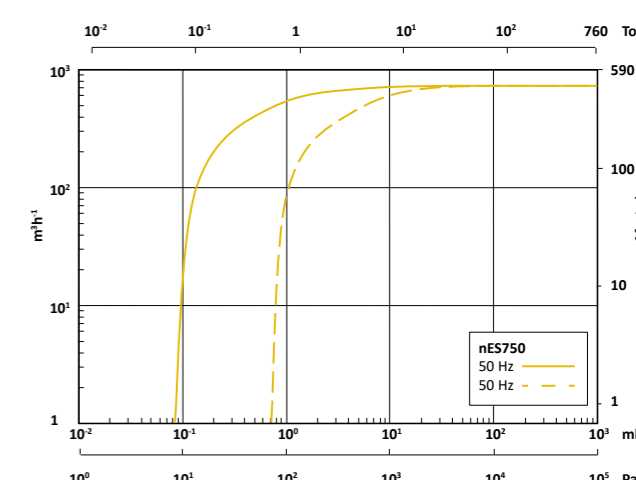

— Without gas ballast
 - - - With gas ballast

APPLICATIONS

The nES series single stage pumps offer an ideal combination of vacuum performance and stability with convenience and investment affordability in a wide range of industrial applications.

Coating

- Load locks of glass coater and large in-line coaters
- Web and roll coating
- Optical, ophthalmic and display coating
- Surface coating like plasma deposition and reflective or decorative

Heat treatment

- Tempering
- Quenching
- Annealing
- Vacuum brazing

Drying

- Transformer drying
- Automotive drying and filling systems
- Refrigeration and air conditioning
- Battery and capacitor drying

General industrial

- E-beam and plasma welding
- Plasma surface treatments
- Oil/resin degassing
- Biogas treatment
- Rubber, silicone and composite
- Leak detection
- Vacuum forming
- Industrial gas production
- Vacuum insulated panels and glass

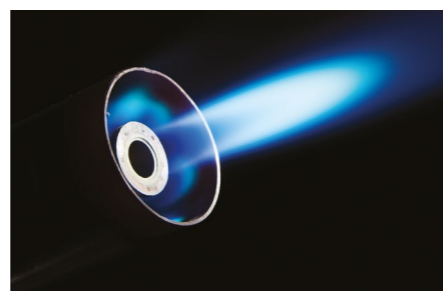
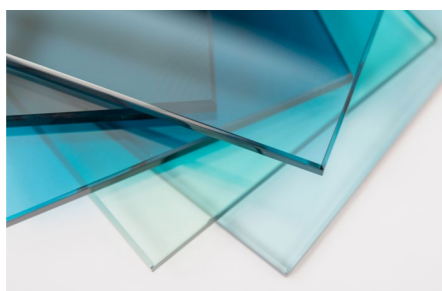

nES PUMP AND BOOSTER COMBINATIONS

Edwards offers a range of nES rotary vane pumps and mechanical boosters, complete with combination kits to mount the mechanical booster. The fitting of a mechanical booster to an nES rotary vane pump significantly increases the pumping speed and vacuum performance of your system as well as the ultimate vacuum attainable.

Edwards can assist you in the selection of the combination most suited to your requirement.

EH range

The EH range of mechanical boosters (250–4200 m³h⁻¹, 150–2500 cfm), with its unique hydrokinetic drive allowing continuous operation from atmospheric pressure to ultimate vacuum, cuts pump downtimes by up to 50%.

Systemisation

Our comprehensive range of nES pumps and EH mechanical boosters, complete with combination kits, allows the user to specify a complete system. Specifying a combination is simply a process of selecting the nES pump and the required mechanical booster that will enable us to build a complete systemised unit ready to use.

Depending on the type of nES and booster pump combination, the assembled unit will either be a Frame Mount or a Direct Mount unit. Alternatively, combination kits are available to allow the nES pump and EH mechanical booster to be assembled at the customer's site.

The nES series is also available without motor (40–300 m³/h). Bare shaft pumps are provided with IEC or NEMA motor flange. Please contact Edwards for additional information.

nES40



nES65



nES100



nES220



nES300/nES300S



nES630



nES750



ORDERING INFORMATION

Model	Motor rating	Voltage	Cooling	Part number
nES40	Wide range	220–230 V & 380–400 V +-10 %; 50 Hz	Air	A35104940
		220–230 V & 380–400 V & 440–460 V +-10 %; 60 Hz		
	Japan	200 V -15 % + 10 %; 50 & 60 Hz	Air	A35104934
	Canada	330 V & 575 V +-10 %; 60 Hz	Air	A35104957
nES65	Wide range	220–230 V & 380–400 V +-10 %; 50 Hz	Air	A35304940
		220–230 V & 380–400 V & 440–460 V +-10 %; 60 Hz		
	Japan	200 V -15 % + 10 %; 50 & 60 Hz	Air	A35304934
	Canada	330 V & 575 V +-10 %; 60 Hz	Air	A35304957
nES100	Wide range	220–240 V & 380–415 V +-10 %; 50 Hz	Air	A35404940
		220–230 V & 380–400 V & 460 V +-10 %; 60 Hz		
	Japan	200 V -15 % + 10 %; 50 & 60 Hz	Air	A35404934
	Canada	575 V +-10 %; 60 Hz	Air	A35402957
nES220	Wide range (including Japan)	200–240 V & 380–415 V +-10 %; 50 Hz 200–230 V & 380–400 V & 440–460 V +-10 %; 60 Hz	Air	A35554950
nES300	Wide range (including Japan)	200–240 V & 380–415 V +-10 %; 50 Hz	Air	A35604950
		200–230 V & 380–400 V & 460 V +-10 %; 60 Hz		
	Canada	575 V +-10 %; 60 Hz	Air	A35604957
nES300S	Wide range (including Japan)	200–240 V & 380–415 V +-10 %; 50 Hz	Air	A35654950
		200–230 V & 380–400 V & 460 V +-10 %; 60 Hz		
	Wide range (including Japan)	200–240 V & 380–415 V +-10 %; 50 Hz 200–230 V & 380–400 V & 460 V +-10 %; 60 Hz	Air	A35904950
nES630	Wide range (including Japan)	200–240 V & 380–415 V +-10 %; 50 Hz	Water	A35905950
		200–230 V & 380–400 V & 460 V +-10 %; 60 Hz		
	NEMA Premium (Class 1 Div. 2)	400 V +/-10% ; 50 Hz 230 V & 440–460–480V +/-10% ; 60 Hz	Air	A35904970
nES750	Wide range (including Japan) 50 Hz only	200–240 V & 380–415 V +-10 %; 50 Hz only	Air	A36904954
		200–240 V & 380–415 V +-10 %; 50 Hz only		
	Wide range (including Japan) 50 Hz only	200–240 V & 380–415 V +-10 %; 50 Hz only	Water	A36905954

SWITCHES, SENSORS AND GAUGES

	Temperature switch	Temperature sensor (PT100)	Oil level switch	Exhaust filter manometer
nES40/65	A35104200	A35900380	A35104205	A35104220
nES100	A35104200	A35900380	A35104205	A35104220
nES220	A35104200	A35900380	A35104205 + GK6542106*	A35104220
nES300/300S	A35104200	A35900380	A35104205	A35104220
nES630/750	A35104204	A35900380	A35104209	A35104220

*End-plate with accessory fitting holes and plugs. Only if required.

nES-EH FITTING KITS

	EH500 (ISO63)	EH1200 (ISO100)	EH2600 (ISO100)
nES100 (ISO40)	A35902100*	-	-
nES220 (ISO63)	A35104101	A35902103	-
nES300 (ISO63)	A35104101	A35104104	-
nES630/750 (ISO100)	-	A35104108	A35104108

*Includes nES100 base-frame

SERVICE AND SUPPORT

Keeping an nES pump working at the top level is paramount, and Edwards offers a **wide range of maintenance service plans**, tailored to your customer's needs. From **Field Service intervention** to **Managed Maintenance contracts**, Edwards will take care of the vacuum pump to ensure **the best performance and longevity of the product** for an optimum total cost of ownership. Further than genuine spare parts, kits and oil, we can provide the following fast and effective service solutions for the nES series pumps:

- Edwards' highly trained Service Technicians can carry out **the commissioning, health check, routine maintenance, troubleshooting and repair of vacuum equipment**, anywhere in the world. We invest in the tools, training and inventory that enable our team of service engineers to deliver quality service in a safe and consistent manner, according to manufacturing recommendations, using genuine Edwards spare parts and oils.
- **Through Managed Maintenance contracts**, Edwards will take over the maintenance planning and responsibility for servicing your nES pumps. Regular scheduled maintenance can identify potential problems before they occur, and plans can be structured around different levels of care. Managed maintenance also enables cost management and will help you to avoid the risk and expense associated with unplanned downtime.
- **With the pump overhaul service** in Edwards' Service Technology Centres located around the world, no matter the condition of your nES pump, our highly trained specialists can handle it, even if coming from harsh environments or critical applications.





Publication Number: 3602 014 1 01
© Edwards Limited 08.2023. All rights reserved.
Edwards and the Edwards logo are trademarks of
Edwards Limited.

Whilst we make every effort to ensure that we
accurately describe our products and services,
we give no guarantee as to the accuracy or
completeness of any information provided in
this brochure.

Edwards Ltd., registered in England and Wales
No. 6124750, registered office: Innovation Drive,
Burgess Hill, West Sussex, RH15 9TW, UK.